

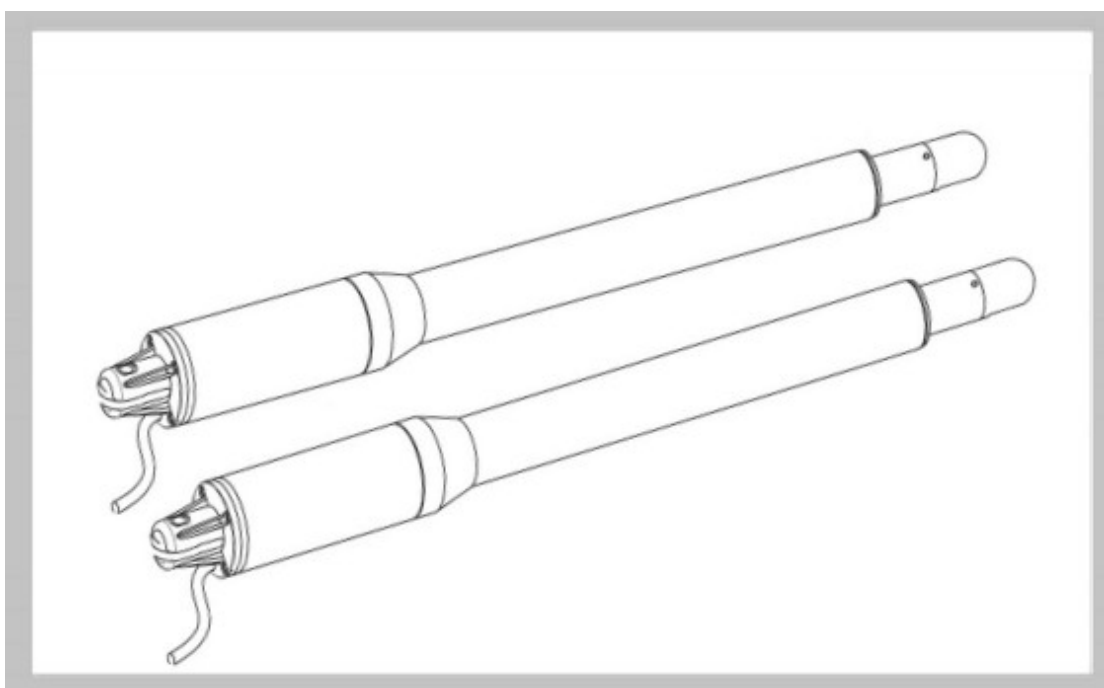

Linear Actuator 24V Swing Gate Opener User Manual



Attention

The manual should be read prior to the
installation process

CAUTION:

- **This product must be installed by well-trained skilled personnel in compliance with the safety regulations the field of residential and commercial swing gate opener devices. Unqualified personnel may damage the instruments And cause harm to the public.**
- **Electric Power must be disconnected prior to installation, or performing any maintenance.**
- **Please read the manual carefully before installation. Incorrect installation or misuse of product may cause seriously damage to users and property.**
- **If the electric cable is damaged or broken, it must be replaced by a whole and properly insulated wires, to avoid electric shock or any hazardous environments.**
- **Keep the wireless transmitters out of children reach.**
- **Do not allow children or other individuals to stand by the path of the motor arms or the path of the gates while in operation.**
- **Do not use the remote wireless transmitters when the gates are out of sight.**
- **Do not install the products in corrosive, inflammable, and/or explosive environments.**
- **Avoid installing the motor arm where the override manual release key is exposed to the public .**

Tools Required

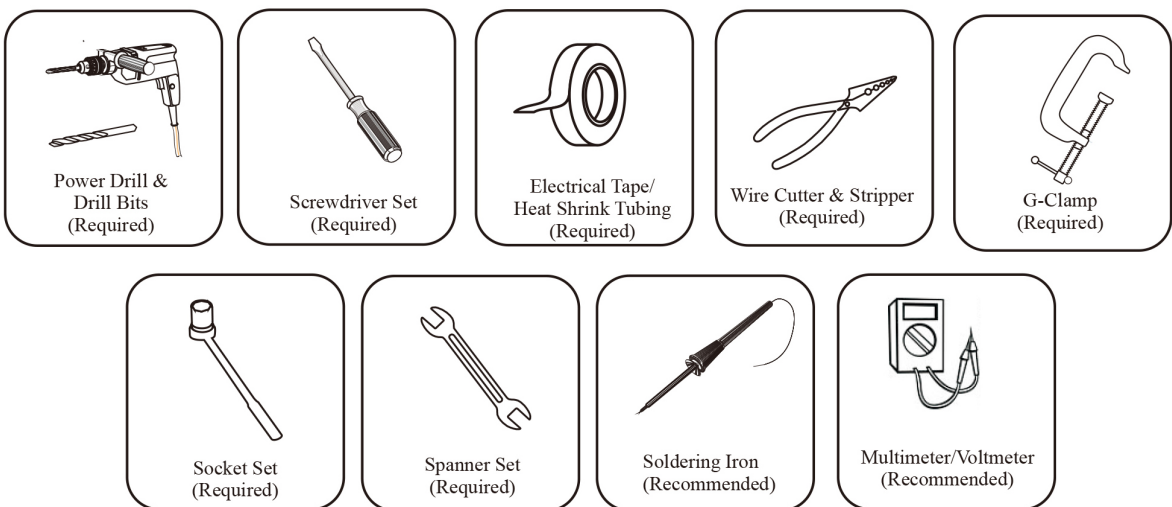

I. Products Configurations:

Products and accessories list



Configuration of Swing Gate Opener PKM-C01 Dimensions are in mm

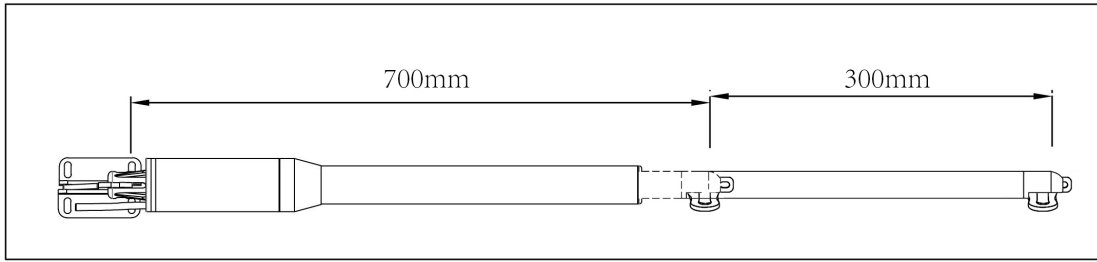

Figure 1

Nomenclature of Swing Gate Motor

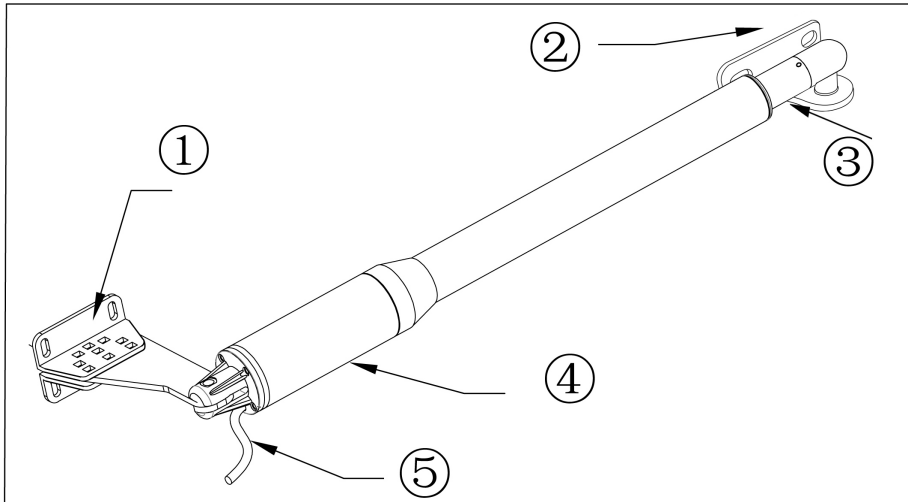

Figure 2

- Item 1:** Post Rear Fixed Bracket
- Item 2:** Gate Front Fixed Bracket
- Item 3:** 300mm Extended Arm
- Item 4:** Motor Box
- Item 5:** Power Cable

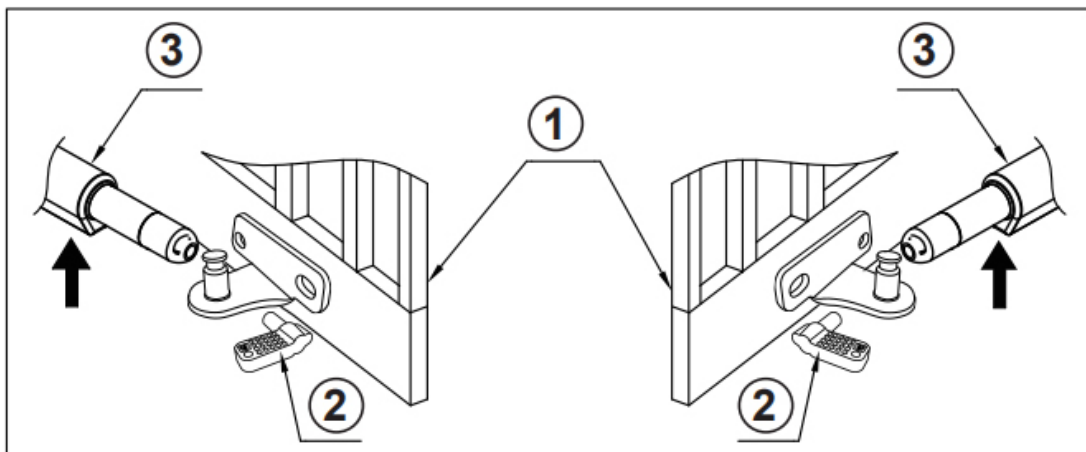

Figure 3

- Item 1:** Gate
- Item 2:** Manually spanner
- Item 3:** Release by spanner then lift it and separate the motor from gate

II. Swing Gate Opener Features & Options:

1. **In case of power failure:** Use the manually spanner to release to separate the motor and gate, open or close the gate manually.
2. **When Gate is Obstructed:** Gate stops .
3. **Optional:** The Gate Opener Controller can be connected to a solar system, a flash light warning, a photocell, back up battery, keypad and other access control devices.
4. **Speed Control:** Gate opening and closing speed can be adjusted.
5. **Gentle Start:** The Gate Opener is equipped with a soft start function.
6. **Auto Close:** The Gate Opener System is equipped with Auto close function with adjustable closing time delay.
7. **Single or Dual Gate:** Either Single or Dual Swing Gate can be opened.
8. **Multiple Remote Transmitters:** The Controller can easily accommodate several unique extra remotes to control the swing gate opener
9. **Battery Back Up:** DC 24V back up battery can be incorporated
10. **Optional Devices:** DC 24V Gate Lock, photocell ,keypad , photocell, push button, large size or small size control box.
11. The Gate Opener can be configured to allow smooth noiseless operation.
12. The Gate Opener can be configured to enable open condition as default, or close condition as default depending on the placement of the provided hardware bracket brackets.

III. Technical Specifications

Motor voltage: 24VDC 40W	Input power: 220VAC ± 10%/120VAC ± 10%
Rotational speed: 250 RPM	Arm's extended speed: 1.6 cm/s
Arm's max travel: 300 mm	Continue running time: 5 minutes
Max single-leaf length: 2.5meters	Max single-leaf weight: 200 KG
Environment Temperature: -45°C ~ +50°C	Protection Class: IP55
Max gate open angle: 110 degree	Dual Swing Gate Gross weight : 15KG

IV. Preparing The Installation Site:

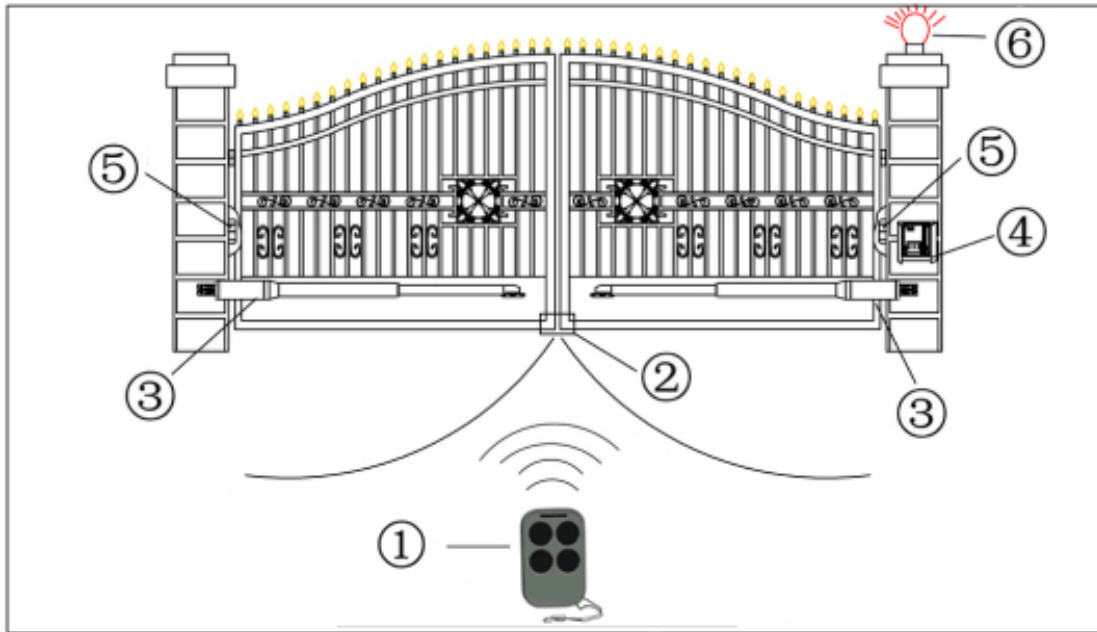

Figure 4

Item	Nomenclature
1.	Wireless Transmitter
2.	Rubber Stopper
3.	Swing Gate Opener Motor
4.	Control Box
5.	Photocell Electric Sensor
6.	Flash Light Alarm (Optional)

V. Rear Bracket Installation Alternatives to Gate Posts

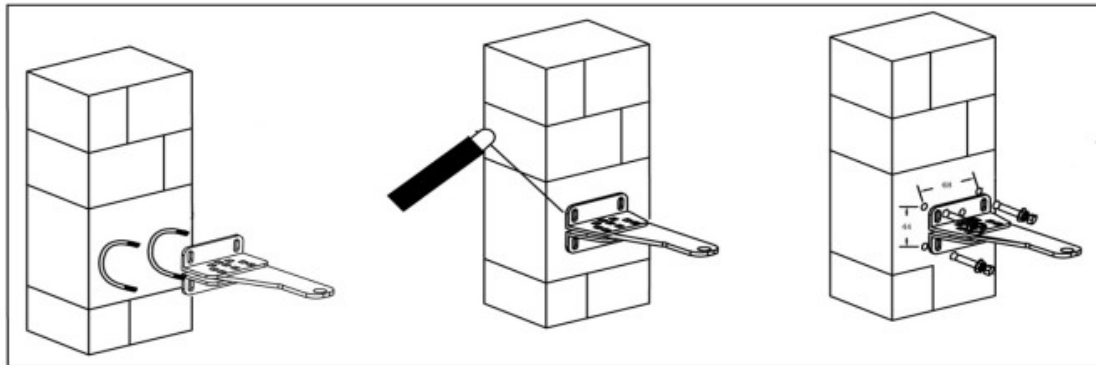

Figure 5

1. **Construction Drill and Bolts, Figure 5 right:**
 - a. Drill 4 Holes of 8mm Diameter
 - b. Insert the 4 Provided Concrete Bolts and Tighten Properly (Do not over tighten as you may strip the bolt out of the concrete or the brick)
 - c. Place the Motor Connecting Bracket and Tighten with the Provided Screws

2. **Construction Drill and Weld, Figure 5 middle:**
 - a. Drill 4 Holes of 8mm Diameter
 - b. Locate the 4 Slotted Holes Post Bracket above the Drilled Holes
 - c. Weld the Motor Bracket to the Post Bracket

3. Precast U Bolts, Figure 5 left:

- a. Locate the 4 Slotted Holes of the Post Bracket above the End of U Bolts
- b. Apply the Appropriate Screws
- c. Place the Motor Connecting Bracket and Tighten with the Provided Screws

4. Adjusting different angles of Rear Bracket Fixed Plate to fit different

Installing condition .

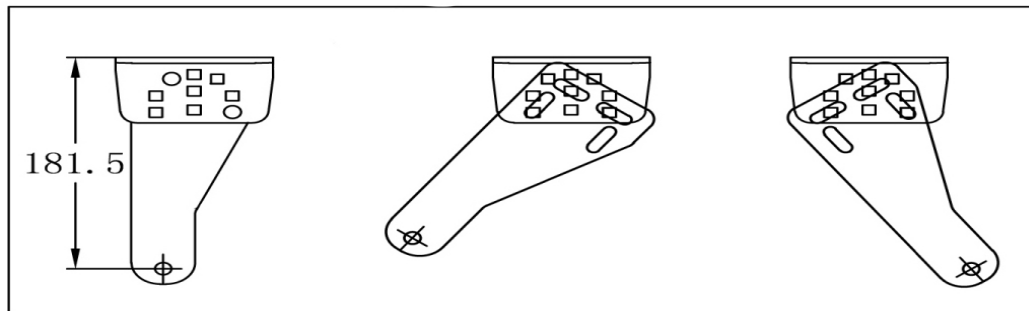

Figure 6

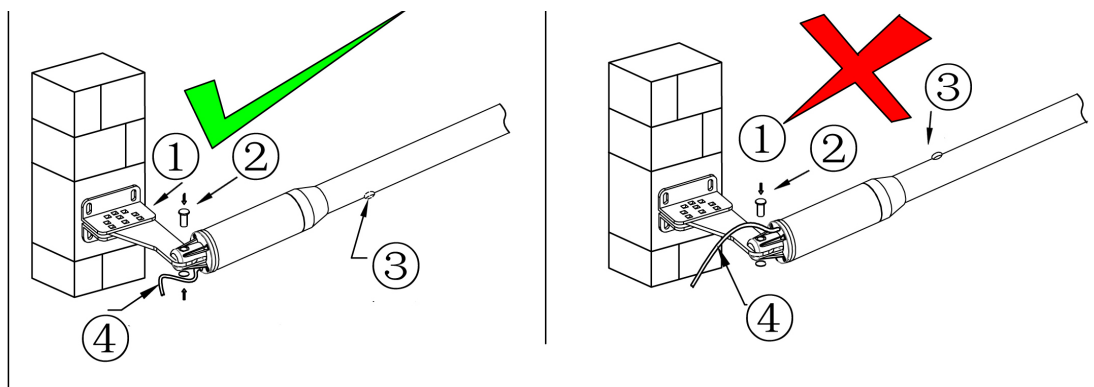

Figure 7

Figure 7 left, Power Cable And Rain Drainage Aperture Placed Correctly

- 1 Post Rear Fixed Bracket
- 2 Lock in

Figure 7 right, Power Cable And Rain Drainage Aperture Placed Incorrectly

- 3 Rain Drainage Aperture
- 4 Power Cable

Notice: Incorrect Installation, Figure 7 right:

Cable must not be installed above the motor arm. It may pinch and strip the cable and causes electric shock. Follow correct installation as shown in Figure 7left.

VII. Installation of Extended or Retracted End Motor Arms to Gates:

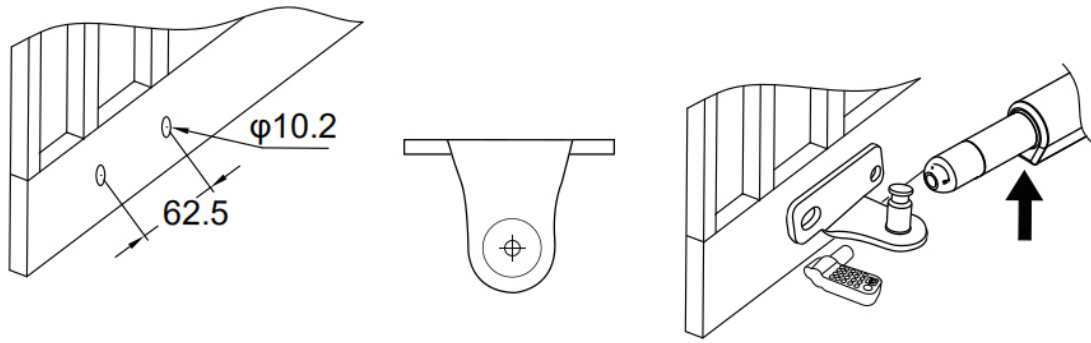

Figure 8

- A.** Drill 2 Holes of 10.2mm Diameter With Space 62.5mm Between 2 Holes
- B.** Locate the 2 Slotted Holes Gate Bracket above the Drilled Holes
- C.** Place the End Motor Bracket to the Gate Bracket using the Appropriate Bolts and Tighten Properly(Please note these bolts used to fixed front bracket to the gate are not provided due to the thickness of each gate is different)
- D.** Insert the Lock Pin and Clamping Washers

VIII.Brackets Height :

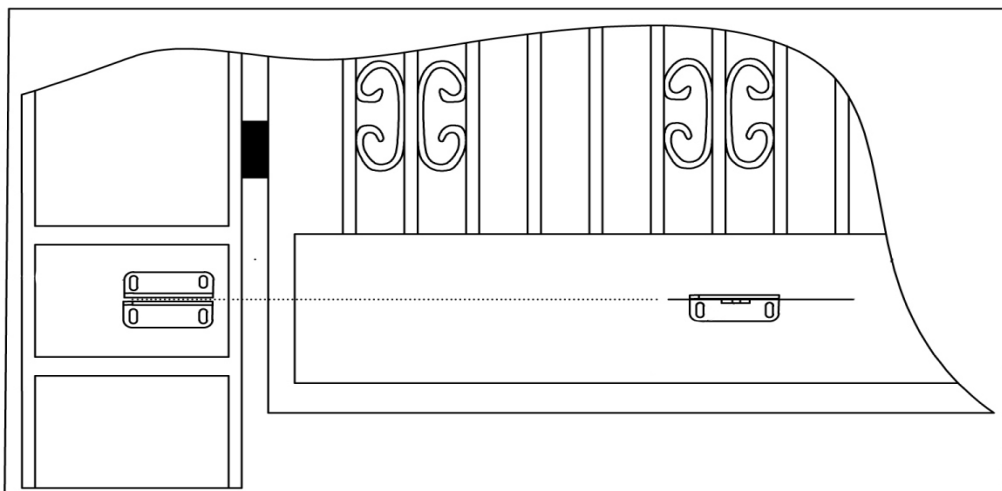

Figure 9

Ensure that the Post bracket height is in the same exact level with the gate bracket height. Failing to ensure accurate common heights will cause the motor arm to bend leading to failure. Also, the force to push or pull the gate will be reduced causing the motor to open or close the gates with difficulty or may not operate successfully at all. Severe different in height will damage the motor and the motor arm.

Configuration of Normally Closed Gate Opener System

There are two installation types for the gate opener, check for Proper Gate Installation & Direction of Gate.

Pull-To-Open Installation Mode:

The installation position of the bracket is very important. Please refer to the figure to measure according to the angle you need to open. Unit: mm (for example: A is 150mm, B is 105mm. At this time, the maximum opening angle of the gate is 110°),

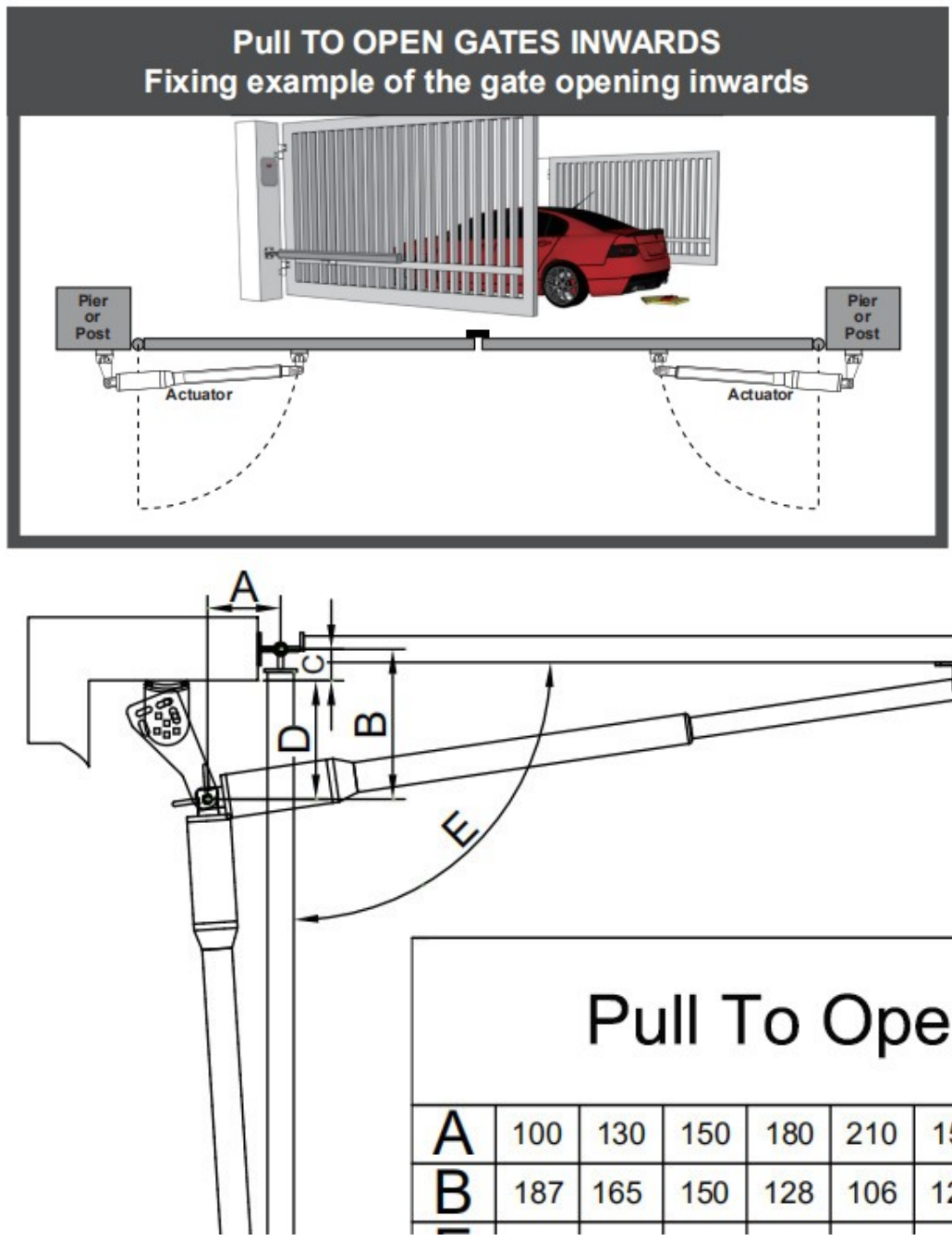

Figure 10

Push to Open Installation Mode

The installation position of the bracket is very important. Please refer to the figure to

measure according to the angle you need to open. determine the center point of the shaft and mark it.

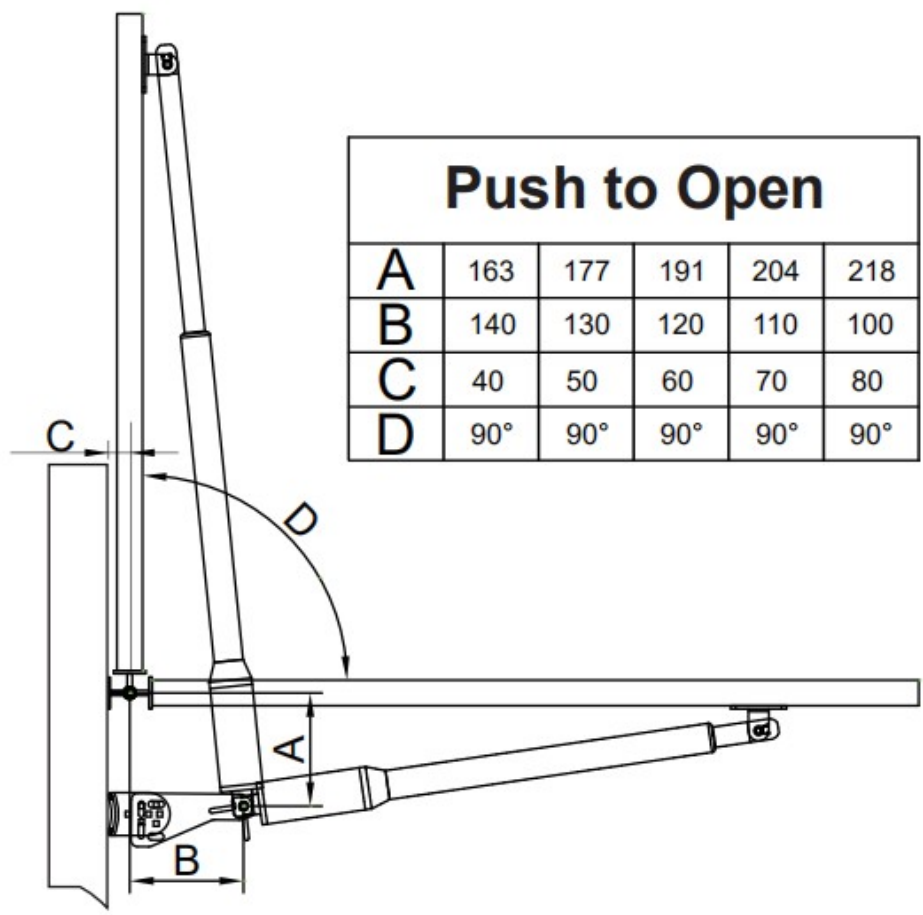
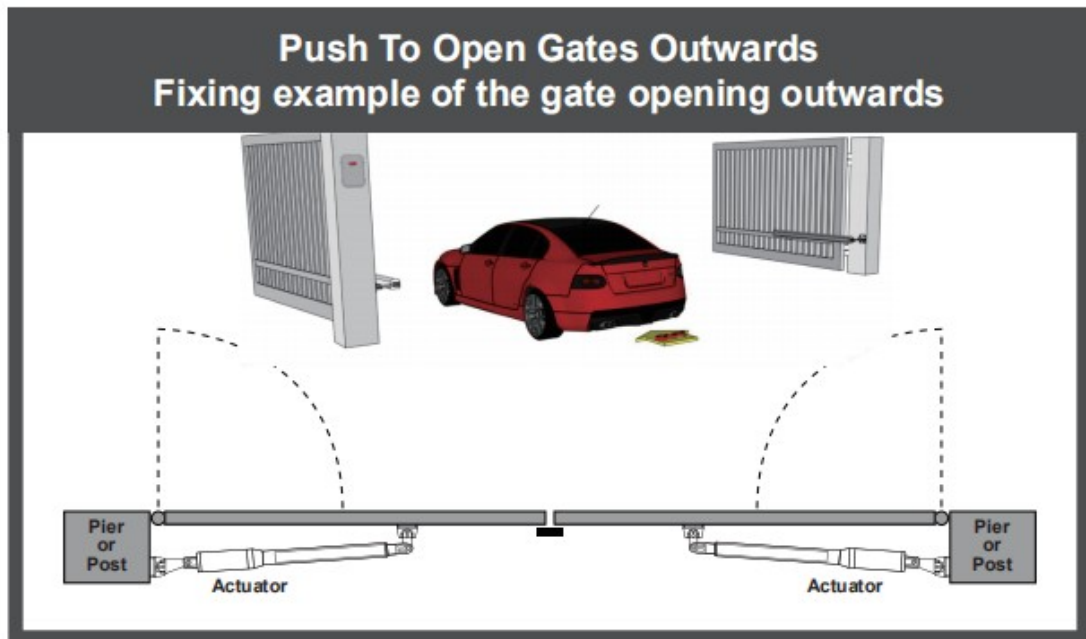
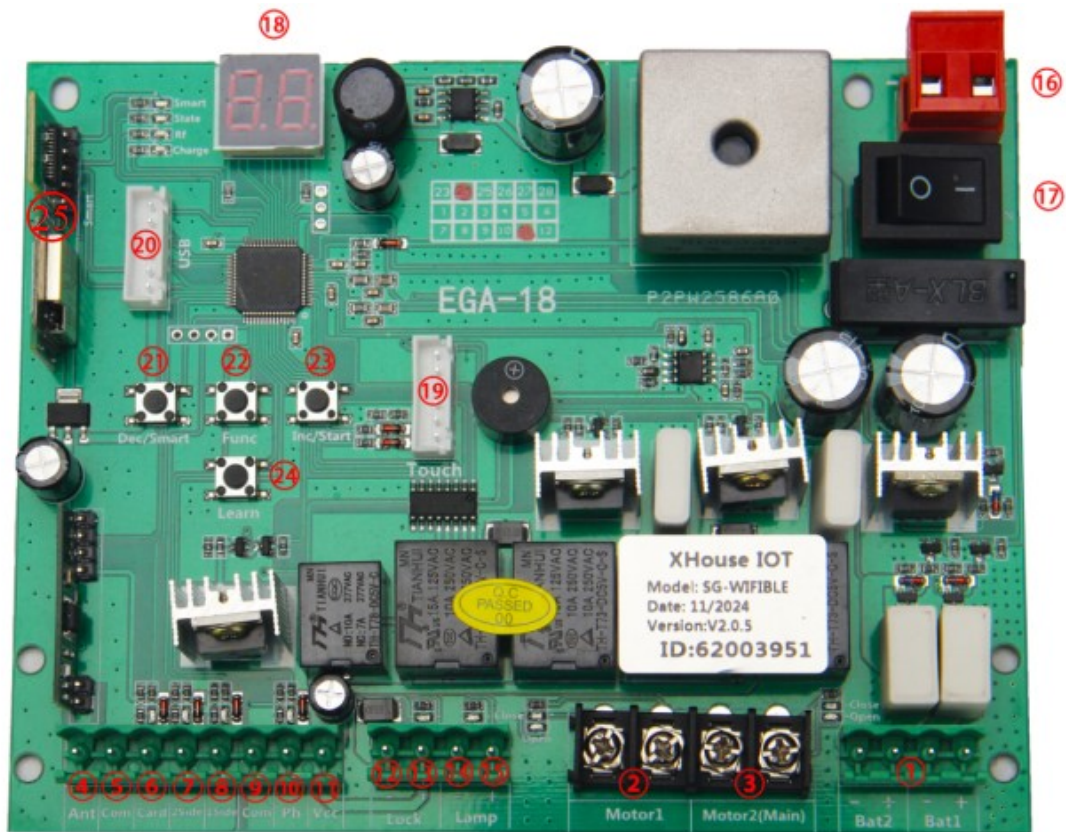

Figure 11

Control board Instruction

Technical Parameters:

1. Control Panel Power: AC 19.6-21.6V DC24-28V
2. Back up battery: 12V lead-acid battery x 2
3. Application: Used for double or single DC 24V swing gate opener.
4. Encoder For transmitter: Factory owns rolling code.
5. Allowed Transmitters Quantity: Up to 128PCS.



1. Battery 1 and 2: connect with 2pcs 12V lead-acid battery.
 2. MOTOR 1: Slave gate, close first & open last.This terminal connects 1st red wire (counted from your left-hand side to your right-hand side)
 3. MOTOR 2 (Main) : Master gate, open first & close last.This terminal connects 1st blue wire (counted from your left-hand side to your right-hand side).
- NOTE! If you only have a single gate, the motor only can connect to the Motor 2 Main terminal.**
4. Ant: Connect with the antenna.
 5. COM: It is for connecting with the COM or GND.
 6. Card: It is for connecting to any external devices that will operate to open the gate.
 7. 2 SIDE: It is for connecting with any external devices that operates a double gate.
 8. 1 SIDE: It is for connecting with any external devices that operates the single gate.
 9. COM: It is for connecting to the COM or GND.
 10. Ph: Infrared terminal is for connecting with the photocell sensor.
 11. VCC: The output is for connecting with the photocell sensor, etc devices, continuous output current $\leq 0.5A$.
 12. Lock -: used for connecting with the “ground” of the lock.
 13. Lock +: used for connecting with the electric lock
 14. Lamp -: It is for connecting with the flash light -.
 15. Lamp +: It is for connecting with the flash light +.
 16. Power: It is for connecting with the AC transformer or DC 24V solar panel.
 17. ON: power on/off button.
 18. Menu: It is a digital display for showing you the setting data.
 19. Touch: It is for connecting with the touch button, etc devices.
 20. USB: It is for connecting with a USB device to upgrade the software.
 21. DEC/Smart: used for figure decreasing of setting the data or operating the smart

module.

22. FUN: Used for enter the menu setting and confirm the data.

23. INC/Start: used for figure increasing of setting the data or operating the single button control mode.

24. Learn: It is for programming/erasing the remote control.

25. Smart module: it is for operating the gate opener by smart phone with WiFi and Bluetooth or 2.G USB card.

Remote Control

Each remote has 4 buttons, can set them with different work mode independently through the digital display menu L1, L2, L3 and L4,

0: No function.

1: Double gates open-Stop-Close...

2: Single gate open-Stop-Close...

3: Turn auto close off via remote

4: Open only.

Program new remote control:

- Press the Learn button on the control board for about 1 second, and the buzzer will sound with a short beep. The digital display will show the remote's number, which means the programming is successful.
- After you press the Learn button, if the board does not receive the new remote signal within 8s, the indicator LED will turn on and exit programming.
- Note: Due to the digital display only can show two digital numbers, if the controller already learned more than 99pcs remote, from the 100th remote, the digital display will show A to replace the ten and hundred digits. Such as the 100th remote will show A0, and the 101st remote will show A1. If the controller already learned more than 109pcs remote, from the 110th remote, the digital display will show b to replace the ten and hundred digits. Such as the 110th remote will show b0. And the 120th remote will show C0.
- **Max capacity:** 128pcs remote. If the digital LED shows “-” with a buzzer short beep 5 times, then means can not learn more remotes.

Erase remote control:

- Press and hold the Learn button for about 6 seconds. If the buzzer sound with a long beep, release the button and the digital display will show 00, which means remove all remotes successfully.

Wire Diagram of the Control Board

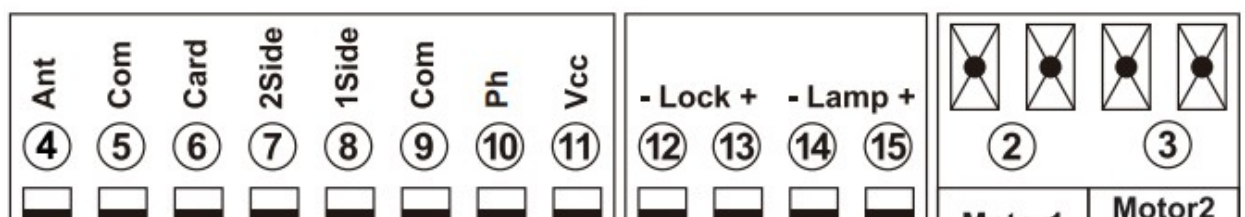

- **Connect with control double gates device**

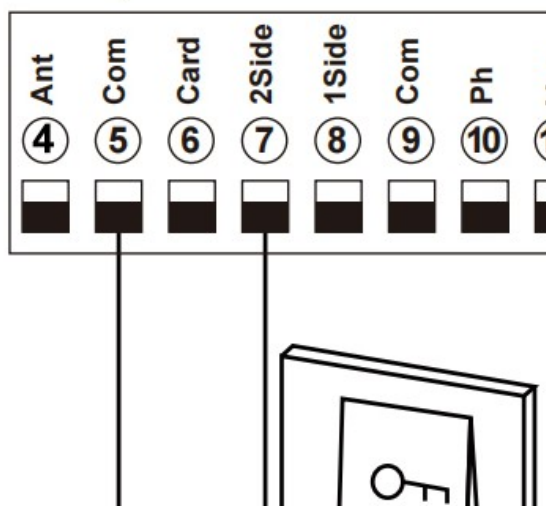

Terminal ⑦2SIDE and ⑤COM are use to connect with push button for controlling dual gates.

If you connect with other control device, please connect with terminal ⑪ and ⑨ to get power supply.

- **Connect with swipe card**

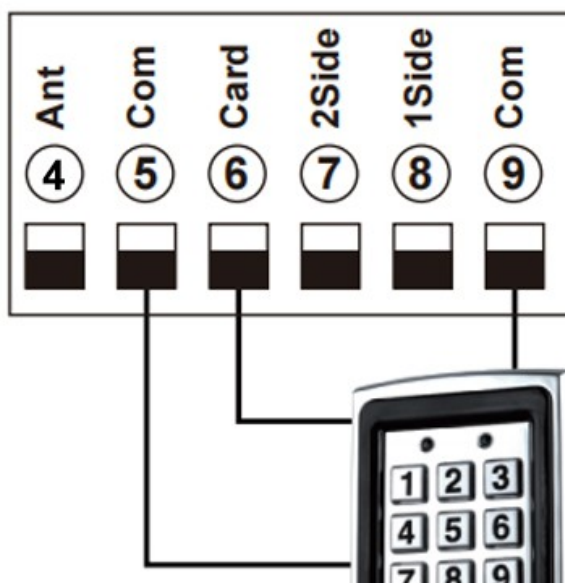

Terminal ⑪VCC and ⑨COM are used to supply power to swipe card device.

Terminal ⑥CARD and ⑤COM are use to connect with swipe card for controlling dual gates.

- **Connect with safety beam**

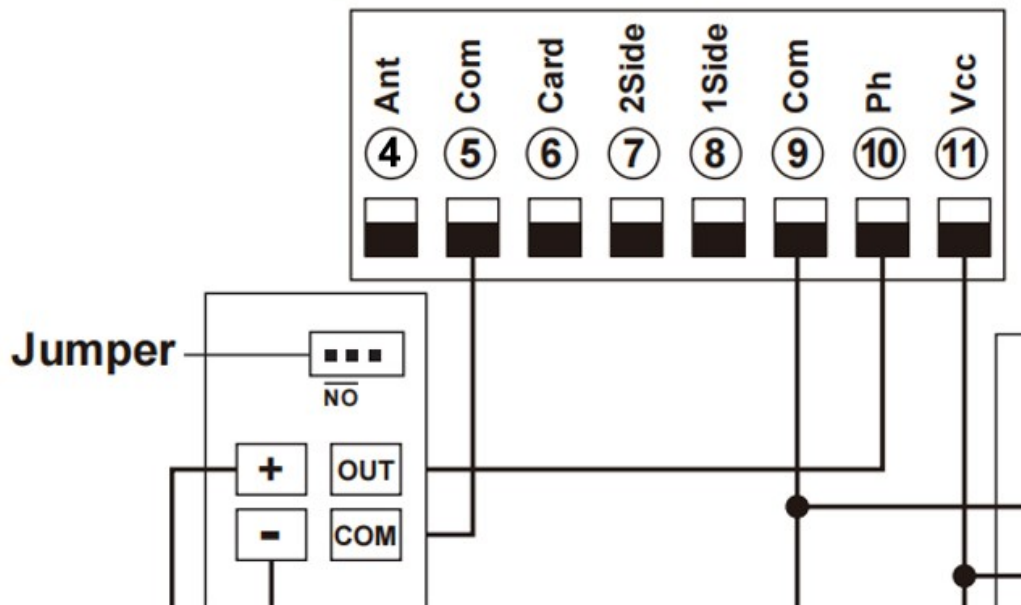

Terminal ⑪ VCC and ⑨ COM are used to supply power to safety beam sensor. So, connect terminal ⑪ VCC with the “+” of the safety beam sensor RX and TX . Connect terminal ⑨ COM with the “-” of the safety beam sensor RX and TX. Connect terminal ⑩ Ph with safety beam sensor “OUT”
Connect terminal ⑤ COM with safety beam sensor “COM”

- **Connection of Flash Lamp Device**

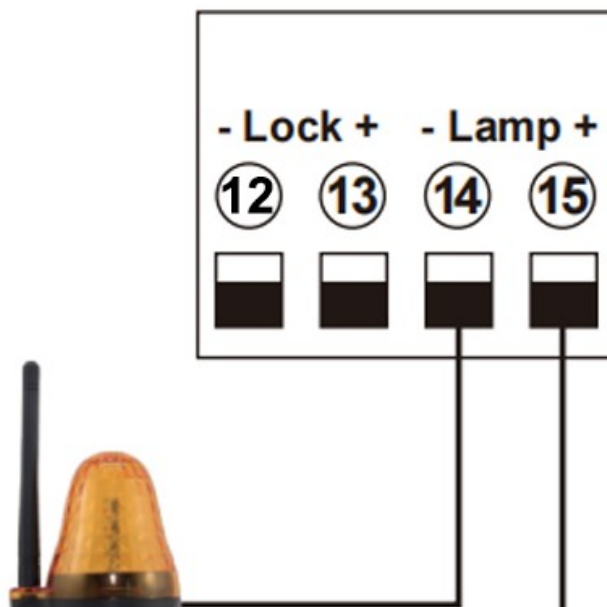

Terminal ⑭ ⑮ Lamp + / - are used to connect with flash lamp.

• **Connect with electric lock**

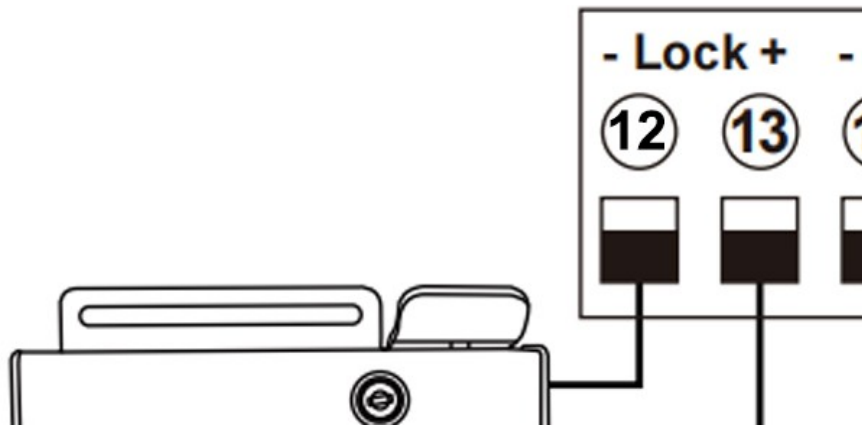

Terminal ⑫LOCK- is used to connect with electric lock blue wire.

Terminal ⑬LOCK+ is used to connect with electric lock red wire.

Function Description of the Control Board

Function	State
Power On	The digital display will show EGA-18 00-U xx with a buzzer sound. If the indicator LED light on, means the system is working well.
Auto travel learning	<p>The newly installed motor needs to operate the auto travel learning once before the high and low speeds can be normally allocated.</p> <p>After the auto travel learning completed, the gate motor will automatically allocated the high and slow speed. The high and slow speeds for opening and closing can be set through the digital display menu.</p> <ol style="list-style-type: none"> 1. Before starting the auto travel learning, the gate must be fully closed. 2. Enter the menu, select Pr, set 5, and confirm to start the auto travel learning <p>Note: Auto travel learning will run at the slow speed set by the digital display menu; the port or remote control cannot be triggered during the learning process, otherwise the auto travel learning will be exited.</p> <p>If Pr set 10, you can also enter the auto travel learning, but this time it runs at the high speed set by the menu.</p> <p>It is recommended to select 5 to use the slow speed to learn the stroke. If after the slow speed auto travel learning, it is found that the high and low speed distribution of some gates is not ideal, you can try to use high-speed auto travel learning.</p>

Setting slow speed running time	<p>After completed the auto-travel learning, the gate opener will automatic set the slow speed running time for opening and closing from 0 - 5 levels. The bigger the value is, the more slow speed running time.</p> <p>0 means No slow speed running time.</p>
Setting running speed for opening and closing	<p>The gate opener can set the high speed and slow speed for opening and closing from 0 - 5 levels. The bigger the value is, the higher speed running.</p> <p>If adjust the running speed, please operate the auto-travel learning again.</p>
Motor overcurrent sensitivity setting	<p>The function can realize to anti crash the car and motor stop while the gate is opened or closed fully. While the gate is moving, it meets obstruction and will stop right now. The motor's overcurrent setting of high speed and low speed can be adjusted by the digital display menu.</p> <p>If the menu H3 set 1, while the gate is closing and detecting the obstruction, the gate will rebound to open fully.</p>
Setting gate type	<p>The menu H4 can set the the gate is common gate or heavy duty gate, factory default is common gate.</p> <p>When the gate weight is heavy in the actual environment, the motor is easy to encounter obstructions and detect an overcurrent. So you need to set menu H4 is heavy duty gate.</p>
Limit mode	<p>The menu H3 can adjust the limit mode of the swing gate system.</p> <p>0 is overcurrent, while the motor runs with low speed and meet the obstacle, then detect the overcurrent, it is judged as a limit.</p> <p>1 is the limit switch. After the door machine runs in place, the limiter is disconnected. The system detects that the limiter is disconnected and determines that it is a limit.</p>
Safety beam mode	<p>The safety beam mode can be be selected by menu, the default mode is 1, it is normal open mode.</p> <p>1. While the gate is closing, if the infrared signal meets an obstruction, the gate will rebound to open.</p> <p>2. If set the auto-closing timer after fully opening, the gate will be auto-closed.</p> <p>2. If the safety beam signal exists, the gate closing action will not be executed and the countdown time will always be reset.</p>
Auto-closing timer for fully opening	<p>1. The auto-closing function is only triggered after the gate is fully opened.</p> <p>2. Auto close timer for fully opening can be set through the digital display menu.</p> <p>3. When auto-close timer start to countdown, the STATE LED will flash one time each second.</p>

	<p>4. The remote button can set to cancel the auto-closing command once.</p> <p>5. Note: Cancellation only cancels this time, and the gate can be auto-closing next time when it is fully opened.</p>
Lamp mode	<p>The lamp work mode can be selected by menu.</p> <p>Mode 0: While the gate is moving, the lamp will light on. While the gate is stop moving, the lamp will turn off.</p> <p>Mode 1: While the gate is moving, and the lamp will light on. After 30s, the lamp will turn off.</p> <p>In addition, regardless of mode 0 or mode 1, the lamp will also light on during the countdown to closing the gate.</p>
Motor working time protection	<p>1.If the motor works continuously more than 60s, the motor will stop running for protection.</p> <p>2. If the motor works continuously with low speed more than 30s, the motor will stop running for protection.</p>
Setting of 1Side terminal	<p>The digital display menu can set the 1 SIDE terminal control mode.</p> <p>0: Double gates "Open-Stop-Close".....;</p> <p>1: Motor 2 "Open-Stop-Close".....(Factory defaults)</p> <p>2: Open only.</p> <p>3: Close only.</p> <p>4: Stop only.</p> <p>Note: mode 1 only apply in the motor 2. Other mode can be apply in double gates or single gate.</p>
Setting of 2Side terminal	<p>The digital display menu can set the 2 SIDE terminal control mode.</p> <p>0: Double gates "Open-Stop-Close".....(Factory defaults)</p> <p>1: Motor 2 "Open-Stop-Close".....</p> <p>2: Open only.</p> <p>3: Close only.</p> <p>4: Stop only.</p> <p>Note: mode 1 only apply in the motor 2. Other mode can be apply in double gates or single gate.</p>
Setting of swipe card terminal triggering	<p>The digital display menu can set the 2 SIDE terminal control mode.</p> <p>0: Double gates "Open-Stop-Close".....</p> <p>1: Motor 2 "Open-Stop-Close".....</p> <p>2: Open only.(Factory defaults)</p> <p>3: Close only.</p> <p>4: Stop only.</p> <p>Note: mode 1 only apply in the motor 2. Other mode can be apply in double gates or single gate.</p> <p>If trigger the swipe card terminal with mode 2 to open the gate fully, it will</p>

	enter the auto closing timer after swiping card.
Touch port	It can connect the touch switch with the control box, has 2 channels. 1.Control the motor 2 by Open-stop-close... 2.Control the motor 1 and motor 2 by Open-stop-close...
Lock mode	1. The lock mode can be switched by menu. 0:NC mode,power on when locked, used for electromagnetic lock.1:NO mode,power on when unlocked, used for electric lock. 2. The control output time of the electric lock can be set by menu. If set to 0, it means turning off the function.
Time delay with 2 gates for opening and closing	Time delay with 2 gates for opening and closing can be adjusted separately by the menu. If user set 0, means No the delay function. If the delay function is active, when opening the door, motor 2 opens first then motor 1 opens later; while closing the door, motor 1 closes first then motor 2 closes. For the single gate system, this function does not work.
Gate mode	1.The gate mode can be switched by menu. 0 is dual gates, which is a double gates opener system. 1 is single gate, which is a single gate opener system. 2.If the system is single gate system, all control for the double gates only operate on the main gate(Motor 2) 3.If it is the single gate system, the motor must be connected with motor2 port.
Smart charger function for back-up battery	1. The system supports two 12V lead-acid batteries in series. 2. The system has a built-in battery balancing function, which will automatically monitor the voltage of the two batteries during charging to prevent the two batteries from being damaged or insufficient due to imbalance. Note: The power port power supply needs to be properly connected, and the input voltage must match the battery to charge the battery normally.
Upgrade control board system by USB device	1. Before you upgrade the system, please confirm the U disk document is FAT32 or not. If not, please format the U disk as FAT32. 2. Copy the upgrade file into the root directory of the U disk and name it EGA-18.bin. 3. Insert the U disk into the upgrade module, and then connect the upgrade module to the USB port. 4. Enter the menu, select the PU and set 5, and confirm. At this time, the system will restart, the digital tube will display UP, and the upgrade will begin. After the upgrade is completed, it will restart automatically.
Smart module port	The XH-SG-WIFIBLE smart module can be connected externally to realize functions such as control, information reading, and settings. The smart

	<p>module includes WiFi, Bluetooth and 2.4G functions.</p> <ol style="list-style-type: none"> 1. Add the Bluetooth control function on the phone APP: Press and hold the DEC/SMART button for 5s, the buzzer will sound twice. Release the button and the module will enter Bluetooth matching network mode. 2. Add the WiFi control function on the phone APP: Press and hold the DEC/SMART button for 10s, the buzzer will sound with a long beep. Release the button and the module will enter the AP matching network mode. 3. Program the 2.4G USB card transmitter: Press the DEC/SMART button once, the buzzer will sound a beep, and enter the programming mode. Power on the 2.4G USB card, and transmit a signal automatically. If the smart LED flash three times, which means the programming operation is successfully. Otherwise, after 8s exit the programming mode. 4.If you want to remove the 2.4G USB card, please press and hold the Learn button for 6s, until the buzzer sound with a long beep, then release the button. After that, all the remotes and USB cards can not control the gate. 5.When the programmed 2.4G USB card enters the receiving range of the module, it will trigger to open the gate once. <p>WiFi and Bluetooth functions support to connect with the phone app, which can realize functions such as controlling the gate with a mobile phone, adding and managing the remote controls, and menu settings the parameters. Please check the APP instruction manual for detailed functions.</p>
Factory Reset	The factory reset needs to be performed at the factory to restore parameters to the default state; see the table below

Digital Display Menu Setting

- Press and hold the [FUN] button for 3 seconds, and the digital display will indicate “A0”, then release the button, now the menu can be set to [INC/START] and [DEC/SMART] for increasing and decreasing numbers or values.
- After adjusting the value, press the [FUN] button to store the data, and the buzzer will beep one time to show the store successfully.
- After the menu setting is finished, press the [LEARN] button to exit the menu setting and close the display.

Item	Function description	Range	Default	Explanation
A0	Motor 2 opening overcurrent setting in high speed	0~20 level	10	Motor 2 opening overcurrent setting in high speed, the bigger the value is, the harder the motor to stop. Setting value from 0-20

A1	Motor 2 closing overcurrent setting in high speed	0~20 level	10	Motor 2 closing overcurrent setting in high speed, the bigger the value is, the harder the motor to stop. Setting value from 0-20
A2	Motor 2 opening overcurrent setting in slow speed	0~20 level	10	Motor 2 opening overcurrent setting in slow speed, the bigger the value is, the harder the motor to stop. Setting value from 0-20
A3	Motor 2 closing overcurrent setting in slow speed	0~20 level	10	Motor 2 closing overcurrent setting in slow speed, the bigger the value is, the harder the motor to stop. Setting value from 0-20
A4	Motor 1 opening overcurrent setting in high speed	0~20 level	10	Motor 1 opening overcurrent setting in high speed, the bigger the value is, the harder the motor to stop. Setting value from 0-20
A5	Motor 1 closing overcurrent setting in high speed	0~20 level	10	Motor 1 closing overcurrent setting in high speed, the bigger the value is, the harder the motor to stop. Setting value from 0-20
A6	Motor 1 opening overcurrent setting in slow speed	0~20 level	10	Motor 1 opening overcurrent setting in slow speed, the bigger the value is, the harder the motor to stop. Setting value from 0-20
A7	Motor 1 closing overcurrent setting in slow speed	0~20 level	10	Motor 1 closing overcurrent setting in slow speed, the bigger the value is, the harder the motor to stop. Setting value from 0-20
A8	Overcurrent sensitivity	0-3 level	0	The bigger the value is, the longer the overcurrent sensing time is. Setting value from 0-3
B0	Setting Motor 2 slow speed running time for opening	0-5 level	2	Setting from 0-5, 0 means NO slow speed running time for opening
B1	Setting Motor 2 slow speed running time for closing	0-5 level	2	Setting from 0-5, 0 means NO slow speed running time for closing
B2	Setting Motor 1 slow speed running time	0-5 level	2	Setting from 0-5, 0 means NO slow speed running time

	for opening			for opening
B3	Setting Motor 1 slow speed running time for closing	0-5 level	2	Setting from 0-5, 0 means NO slow speed running time for opening
C0	Auto-closing timer for fully opening	0-99 seconds	0	Setting from 0-99 seconds, 0 means No auto-closing for fully opening.
C1	Auto-closing timer for swipe card terminal triggering	0~99 seconds	0	0 means No auto-closing for swipe card terminal triggering.
D0	Speed of Motor 2 high speed for opening	0-5 level	5	Setting speed of high speed for opening, setting from 0-5
D1	Speed of Motor 2 high speed for closing	0-5 level	5	Setting speed of high speed for closing, setting from 0-5
D2	Speed of Motor 2 slow speed for opening	0-5 level	2	Setting speed of slow speed for opening, setting from 0-5
D3	Speed of Motor 2 slow speed for closing	0-5 level	2	Setting speed of slow speed for closing, setting from 0-5
D4	Speed of Motor 1 high speed for opening	0-5 level	5	Setting speed of high speed for opening, setting from 0-5
D5	Speed of Motor 1 high speed for closing	0-5 level	5	Setting speed of high speed for closing, setting from 0-5
D6	Speed of Motor 1 slow speed for opening	0-5 level	2	Setting speed of slow speed for opening, setting from 0-5
D7	Speed of Motor 1 slow speed for closing	0-5 level	2	Setting speed of slow speed for closing, setting from 0-5
F2	Safety beam mode	0-1	1	0: NC mode. 1: NO mode.
F3	Flash Lamp Mode	0-1	0	0: Flashing light and motor will operate and stop at the same time. 1: Flashing light will turn off 30 seconds after the motor stop.
F6	Lock mode	0: NC 1: NO	1	NC mode: Normal close, power on when locked, used

				for electromagnetic lock. NO mode: Normal open, power on when unlocked, used for electric lock.
F7	Electric lock working time setting	0~5 seconds	2	Used for setting the working time of electric lock. Setting from 0-5 seconds. 0 means electric lock disabled.
G1	Setting of swipe card terminal	0-4	2	0: Fully Open-Stop-Closefor double gates 1: Fully Open-Stop-Closefor single gate 2: Open only. 3: Close only. 4: Stop only.
G3	Setting of 1 Side terminal	0-4	1	0: Fully Open-Stop-Closefor double gates 1: Fully Open-Stop-Closefor single gate 2: Open only. 3: Close only. 4: Stop only.
G4	Setting of 2 Side terminal	0-4	0	0: Fully Open-Stop-Closefor double gates 1: Fully Open-Stop-Closefor single gate 2: Open only. 3: Close only. 4: Stop only.
H0	Time delay with gate for opening	0-15 seconds	2	0 means No time delay for opening 2 gates
H1	Time delay with gate for closing	0-15 seconds	2	0 means No time delay for closing 2 gates
H2	Gate mode	0~1	0	0: double gates (Motor 1 and 2). 1: single gate(Motor 2).
H3	Limit mode	0~1	0	0: overcurrent. 1: Limit switch.
H4	Setting gate type	0-1	0	0: common gate. 1: heavy duty gate.
L1	Button A function (Remote control)	0-4	2	0: No function. 1: Double gates open-stop-close... 2: Single gate open-stop-close... 3: Turn auto close off via

				remote 4: Open only.
L2	Button B function (Remote control)	0-4	1	0: No function. 1: Double gates open-stop-close... 2: Single gate open-stop-close... 3: Turn auto close off via remote 4: Open only.
L3	Button C function (Remote control)	0-4	0	0: No function. 1: Double gates open-stop-close... 2: Single gate open-stop-close... 3: Turn auto close off via remote 4: Open only.
L4	Button D function (Remote control)	0-4	0	0: No function. 1: Double gates open-stop-close... 2: Single gate open-stop-close... 3: Turn auto close off via remote 4: Open only.
Pr	Trigger auto travelling learning	0-10	0	Setting from 0-10. Set 5 will trigger the auto travel learning with slow speed. Set 10 will trigger the auto travel learning with high speed.
PU	Upgrade the system by USB device	0-10	0	Setting from 0-10. Set 5 will trigger to upgrade the system. 0 means No upgrade the system.
Po	Factory reset	0-10	0	Setting from 0-10. Set 5 will trigger to reset operation. 0 means No reset.

Control board digital display information show:

1. When the gate is opening, the digital display will show motor 1 is “OP”, motor 2 is “OP.”, and open double gates will show“O.P.”
2. When the gate is closing, the digital display will show motor 1 is “CL”, motor 2 is “CL.”, and open double gates will show“C.L.”
3. After the gate stop moving, the digital display will show the motor 1 is “--”, motor 2 is “--.”, and double gates will show “-.-.”
4. When the motor is running at high speed and triggering the overload protection, the digital display will show motor 1 is “OH”, and motor 2 is “OH.”, and double gates will show “O.H.”
5. When the motor is running at slow speed and triggering the overload protection, the digital display will show motor 1 is “OL”, and motor 2 is “OL.”, and double gates will show “O.L.”
6. When the motor reaches max working time, the digital display will show motor 1 is “EC”, and motor 2 is “EC.”, and double gates will show “E.C.”
7. When the safety beam is activated, the digital display will show “PH”
8. When the gate is opened fully, the motor 1 will show “LO”, and the motor 2 will show “L.O”
9. When the gate is opened fully, the motor 1 will show “LC”, and the motor 2 will show “L.C”
10. Cancel the auto-closing, the digital display will show "CC"

Motor direction identification:

When the motor is running, if the motor direction LED indicator is blue, now the motor should be in “opening” operation. When the motor direction LED indicator is RED, the motor should be in the “closing” operation.

Smart Module Instruction

Search “XHouse IOT” and download it from Google play or App Store



FOR Android & IOS

- Or scan this QR code for download APP “XHouse IOT” and install it.

Register the account for “XHouse IOT”and log in.

Add the device

Step 1. Power on the device, open the APP. Press the “⊕” on the top right corner to add the device, then select the“Swinging Gate”which has a orange cycle on the top right corner. (Fig 1 and 2)

- ★ If there has a gray cycle on the top right corner, that means the device already be added. The user need to press and hold the “Dec/Smart” button for about 5s on the control board, then repeat the step 1.
- ★ If there has a message “Please enter distribution network mode and add devices”, the user need to press and hold the “Dec/Smart” button for about 5s on the control board, then repeat the step 1.

Step 2. Select the Wi-Fi, click the “Connect” and enter the password.(Fig 3)

(If there hasn’t Wi-Fi can be connected, the user also can select the “Bluetooth Add” and use the Bluetooth function to control the gate nearly.

Please follow the step 4).

Step 3. Add the device successfully. The user can modify the name of the device and button from the “⚙️” on the top right corner. (Fig 5)

Step 4. Bluetooth Add: If the WiFi network is failure, you can choose the Bluetooth Add. When using Bluetooth mode control the device, the mobile app must be closed to the device within Bluetooth range for about 10m to connect and control it. (Fig 3 and Fig 4).

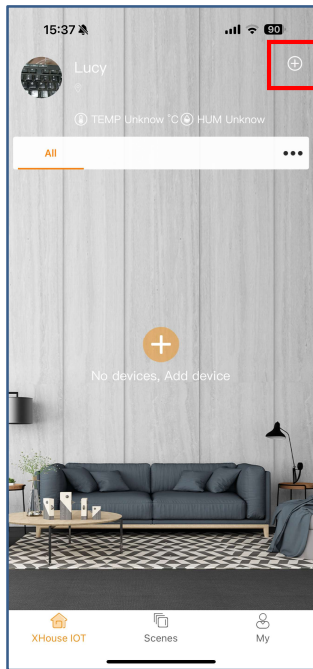

Fig 1

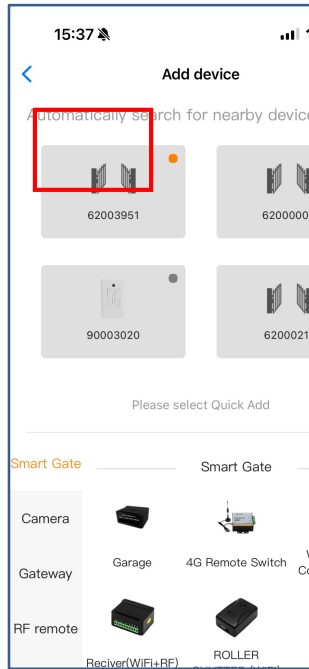

Fig 2

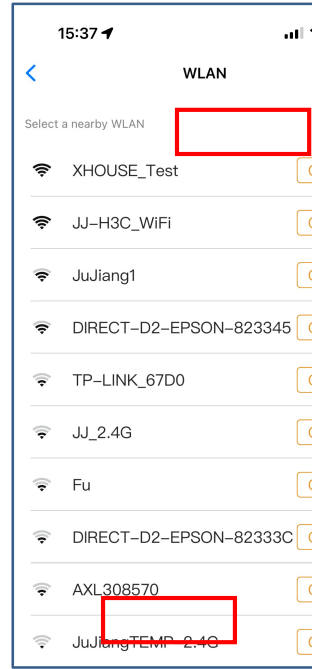

Fig 3

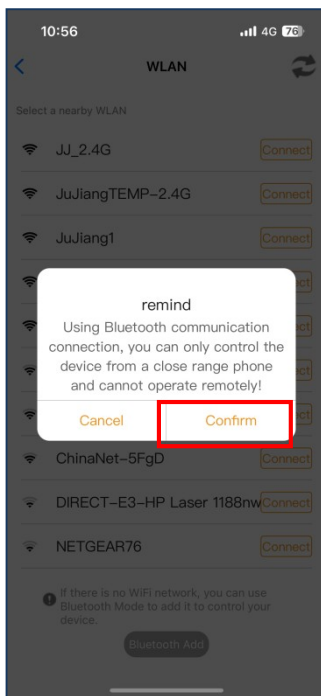

Fig 4

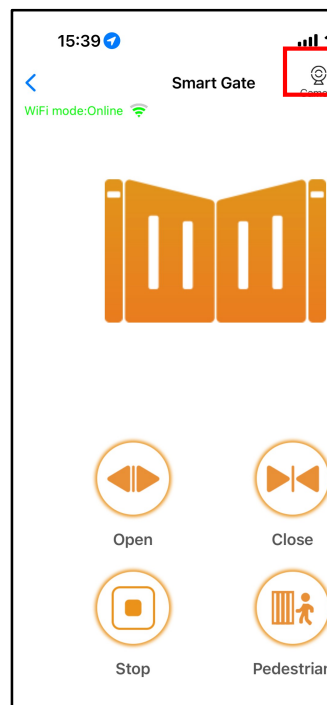

Fig 5

Device supports WiFi and Bluetooth working mode

★ When the device is connected to WiFi network successfully, it supports remote control and settings the device through the mobile phone APP. (Fig 5)

- ★ When the device is offline or the mobile phone has no network, if the user is nearly the device within 10 meters, and open the APP, it will automatically switch to the Bluetooth mode to control the device. (Fig 6)
- ★ The device will establish a Bluetooth connection with the mobile phone to achieve close-range Bluetooth control (only one user's mobile phone can establish a Bluetooth connection at the same time).

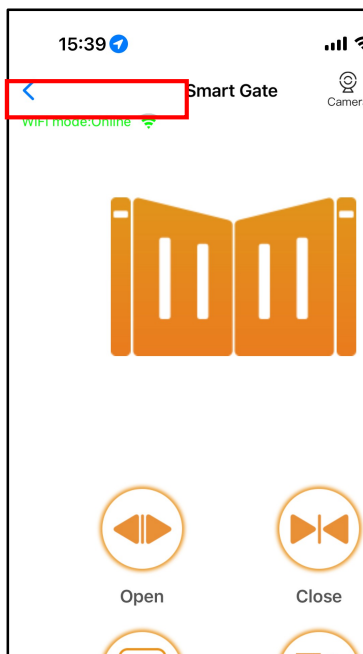

Fig 5

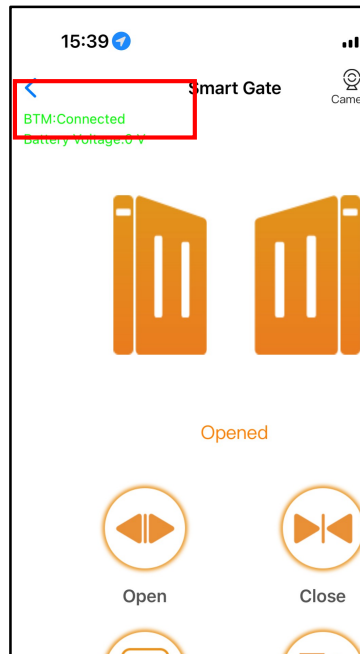

Fig 6

Switch a new WiFi network or switch the Bluetooth mode to WiFi mode

If the user need to switch to use a new WiFi network or want to switch control mode from the Bluetooth mode to WiFi mode, please follow the steps.

Step 1. Select the device, press the “⚙️” on the top right corner. Click the “Set/Modify WiFi”. (Fig 7)

Step 2. Select the new WiFi and connect it. And click the “Refresh”. (Fig 8)

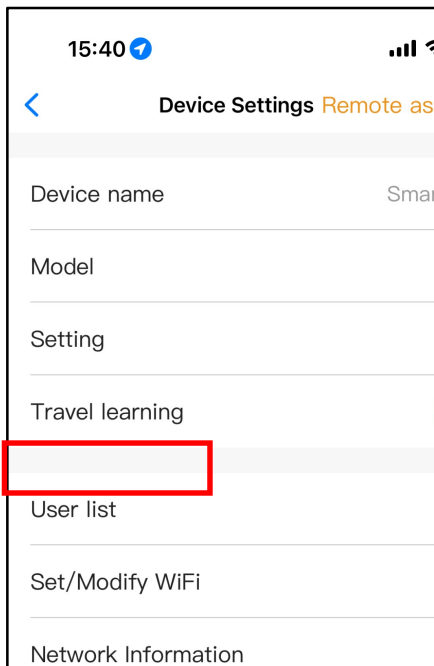

Fig 7

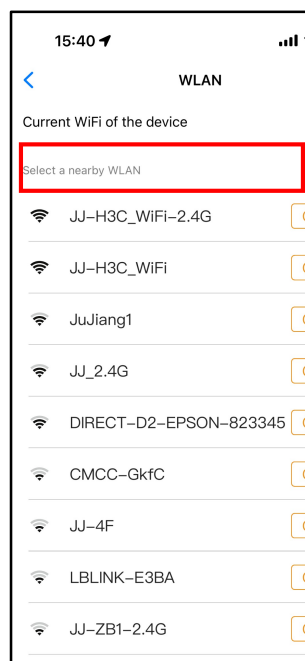

Fig 8

Share the device

Step 1. Open the APP, select the device. Press the “⚙️” on the top right corner, then select to “Sharing device”, will create a QR code. (Fig 9)

Step 2. The new user download the APP and open it, Press the “Scan” on the top right corner to scan the QR code.(Fig 10)

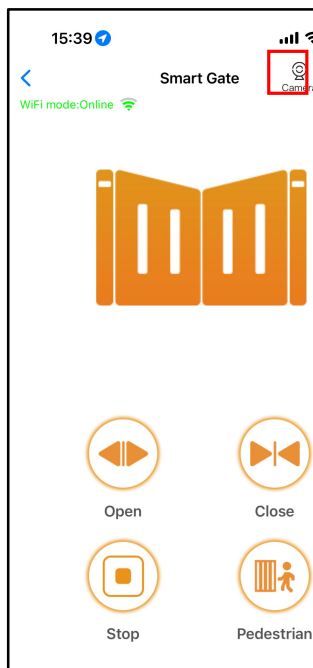

Fig 9



Fig 10

Device settings

The user can set the parameters from the APP for the control board.

Step 1. Select the device, press the “⚙️” on the top right corner. Click the “ Setting”.

(Fig 11)

Step 2. Set the parameters on the APP.(Fig 12)

Note: While the user want to set the parameters, the device must connect with the Wi-Fi. If not, the user need to use the Bluetooth function and put the phone app as close as the device to set the parameters. After done, please click the “Sync” button.

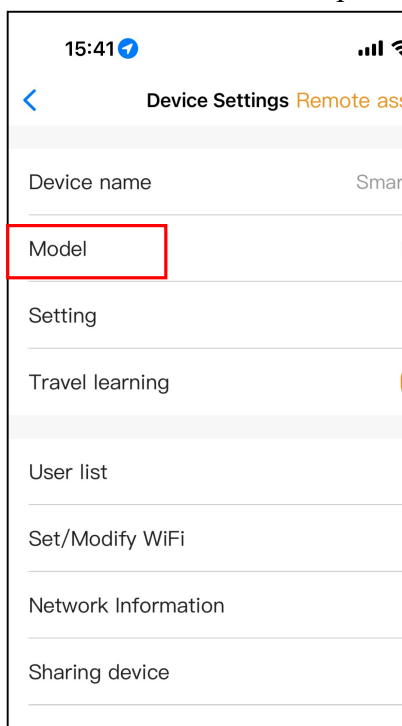

Fig 11

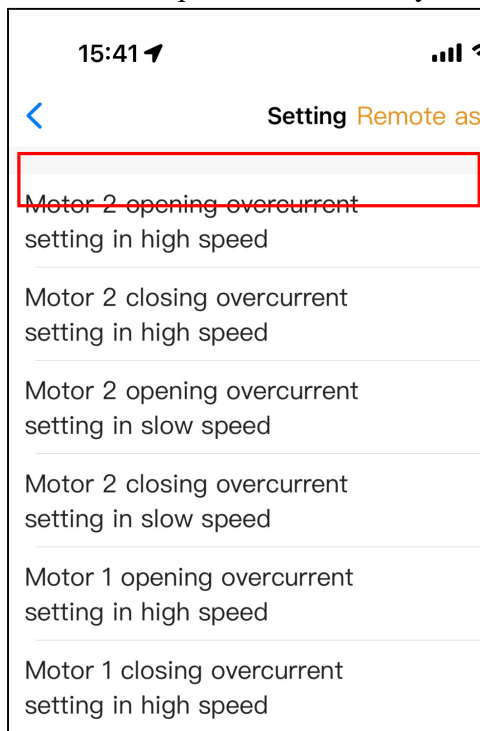

Fig 12

Apply to be engineer

When your customer’s equipment fails, you can solve the problem by “Remote Assistance”. So you need to apply to be engineer on the APP first. Click the “My” in

the bottom of the APP, select “Apply to be engineer”, enter the information to “Confirm application”.

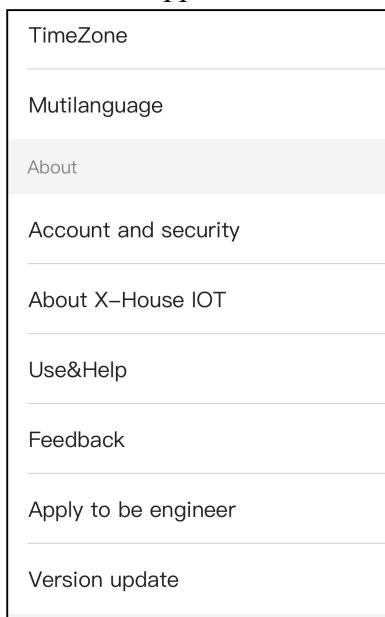

Fig 13

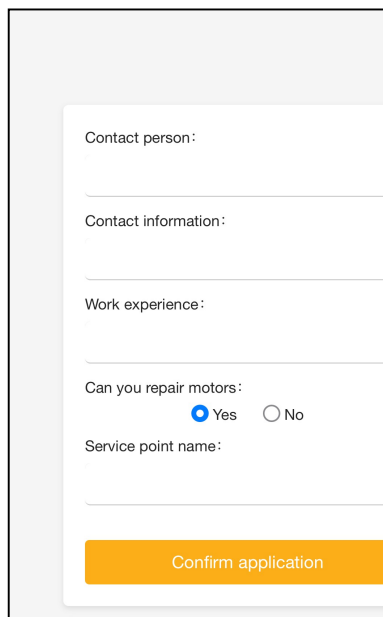

Fig 14

Remote assistance

When your equipment fails, the parameter settings need to be readjusted. At this time, you can directly initiate the “Remote Assistance” button and share the QR code or verification code with your installation service provider for the remote service.

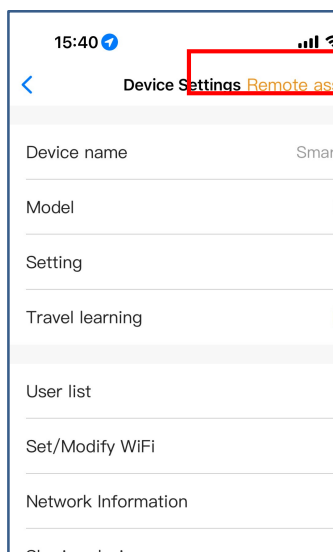

Fig 15

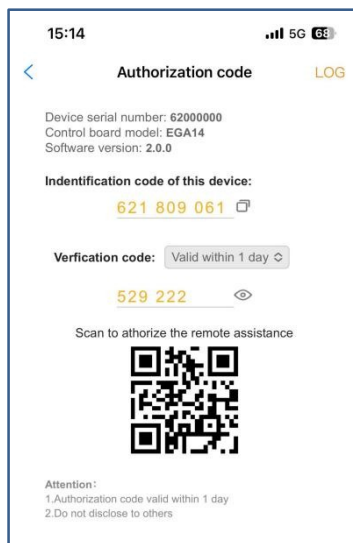

Fig 16

Add USB card / RF remote off site

When the user need to add a RF remote control or a USB card to open the gate, you can use the “Add USB card / RF remote off site” function to do it, and scan the QR

code from the remote control or enter the ID number for the USB card. Don't need to open the control box to program them.

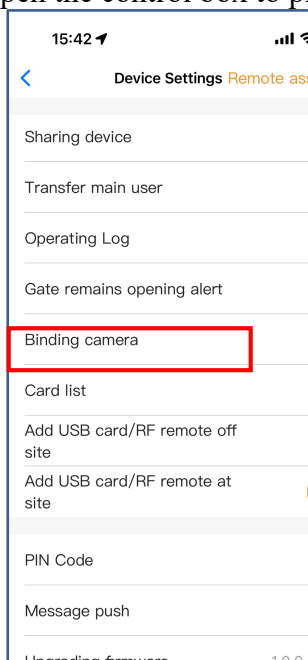

Fig 17

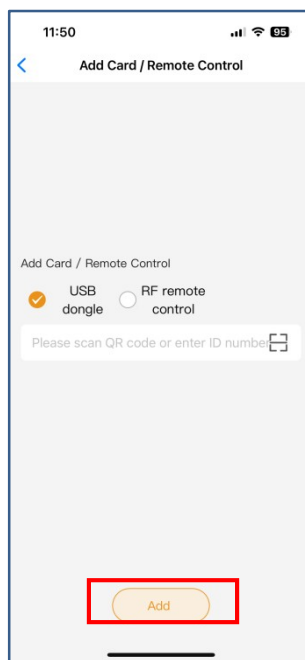

Fig 18

Add USB card/RF remote at site

When the user needs to add an RF remote control or USB proximity card to open the door, you can directly use the "Add proximity card/RF remote control" function, click the "Learn" button, and click "Start Learning". Don't need to open the control box, and the control board will enter the code learning state, and then press the remote control button or power on the USB card to transmit a signal.

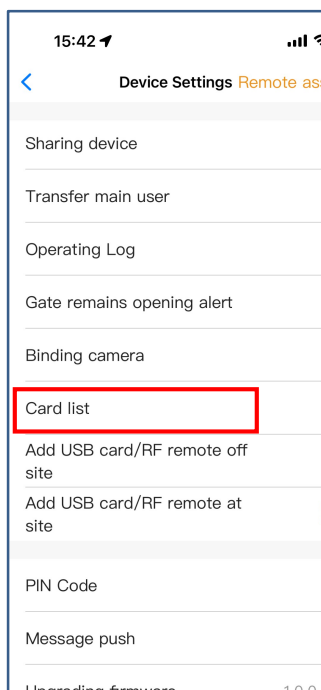

Fig 19

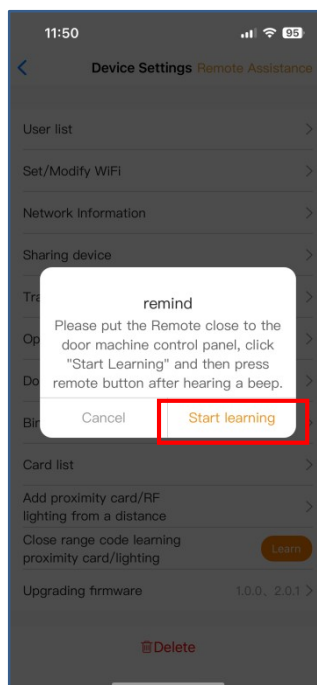

Fig 20

Management of the USB card and RF remote control

The card list can management your USB card and RF remote control. The user can sync all the cards and remotes to the card list for management, and delete it when they

are no longer needed or lost.

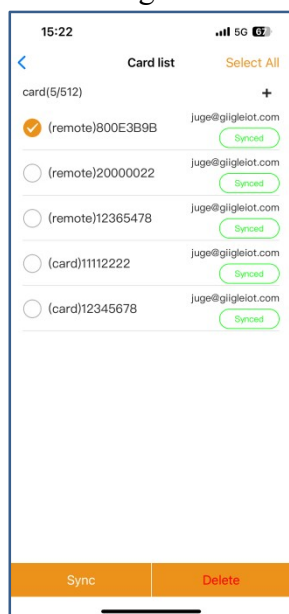

Fig 21

Binding with camera

Step 1. Open the APP, select the device. Press the “ ⚙️ ” on the top right corner, then select to “ Binding camera ”.

Step 2. Select the “ IP camera ”, and press the “ Confirm ”.

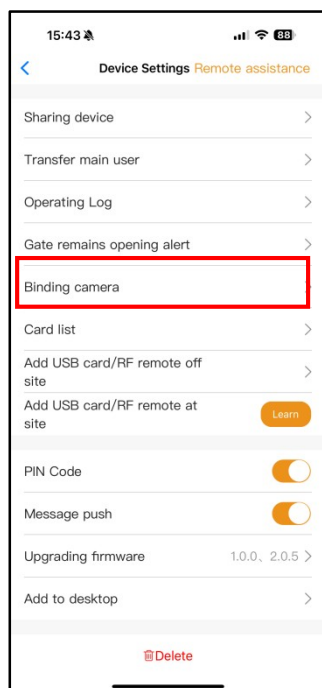

Fig 22

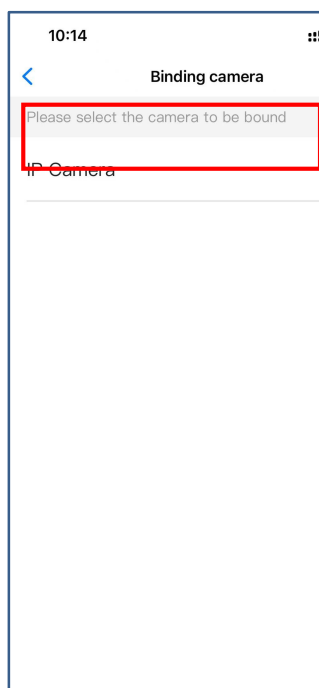

Fig 23